

**Model: 65EOZ (60 Hz)
55EFOZ (50 Hz)**

KOHLER POWER SYSTEMS

3-Phase Diesel

ISO 9001
KOHLER
POWER SYSTEMS
NATIONALLY REGISTERED

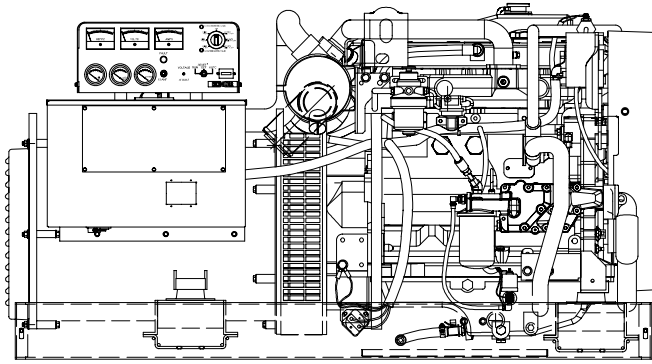

Marine Generator Set

Generator Features

- Remote control connector
- Class H insulation
- Reconnectable voltage
- 60/50 Hz field adjustable generator set
- One- or three-phase reconnectable alternator
- Voltage regulation of $\pm 2\%$
- Frequency regulation of $\pm 5\%$

Optional Accessories

- Sound shield
- Power takeoff (PTO)
- Electronic governor
- Paralleling governor
- Circuit breakers

Generator Weights and Dimensions

	Without Sound Shield	With Sound Shield
Weight, kg (lb.)		
Wet	1057 (2330)	1120 (2470)
Dry	1036 (2285)	1100 (2425)
Length, mm (in.)*	1737 (68.39)	1870 (73.62)
Width, mm (in.)	767 (30.20)	767 (30.20)
Height, mm (in.)	956 (37.63)	1035 (40.75)

* Add 181 mm (7.14 in.) to the unit's length if the unit has the 12/24-volt electric clutch PTO option.

See the drawings on the last page for detailed dimensions.

Generator Ratings

Model Series	Voltage	Hz	25° C (77° F) Amps	Continuous Rated kW/kVA (25° C)	Ph
65EOZ	120/208	60	226	65/81	3
	120/240	60	196	65/81	3
	120/240	60	250	60/60	1
	127/220	60	213	65/81	3
	139/240	60	196	65/81	3
	220/380	60	124	65/81	3
	277/480	60	98	65/81	3
55EFOZ	110/190	50	209	55/68.8	3
	110/220	50	181	55/68.8	3
	110/220	50	245	54/54	1
	220/380	50	105	55/68.8	3
	230/400	50	99	55/68.8	3
	240/416	50	95	55/68.8	3

RATINGS: Marine continuous ratings per ISO 3046, ISO 8528-1, and Kohler ISO rating guideline 2.14. Obtain technical information bulletin (TIB-101) on ratings guidelines for complete ratings definitions.

Availability is subject to change without notice. Kohler Co. reserves the right to change the design or specifications without notice and without any obligation or liability whatsoever. Contact your local Kohler generator set distributor for availability.

Application Data

Engine

Engine Specifications	60 Hz	50 Hz
Manufacturer	John Deere	
Model	4045TFM	
Type	Inline, 4-cycle	
Number of cylinders	4	
Firing order	1-3-4-2	
Aspiration	Turbocharged	
Displacement, L (cu. in.)	4.5 (276)	
Bore and stroke, mm (in.)	106 x 127 (4.19 x 5.00)	
Compression ratio	17.0:1	
Combustion system	Direct injection	
Rated rpm	1800	1500
Maximum power at rated rpm, HP	95	76
Cylinder block material	Cast iron	
Cylinder head material	Cast iron	
Piston rings	2 compression/1 oil	
Crankshaft material	Forged steel	
Connecting rod material	Forged steel	
Governor type	Mechanical (standard) Electric (optional)	

Engine Electrical

Engine Electrical System	60 Hz	50 Hz
Battery, voltage	12- or 24-volt spec	
Battery, charging (12 volt)	65 amp	
Battery, charging (24 volt)	40 amp	
Battery, recommendation (minimum, 12 volt)	640 CCA	
Starter motor	Gear-reduction type	

Cooling

Cooling System	60 Hz	50 Hz
Capacity, L (U.S. qt.) (approx.)	14 (15)	
Cooling type	Heat exchanger	
Seawater pump type	John Deere gear driven	
Seawater pump suction lift, maximum, m (ft.)	0.9 (3.0)	
Heat rejected to cooling water at rated kW, wet exhaust, kW (Btu/min.)	49 (2800)	40 (2275)
Engine water pump flow, Lpm (gpm)	144 (38)	121 (32)
Seawater pump flow, Lpm (gpm)	83 (22)	68 (18)

Fuel

Fuel System	60 Hz	50 Hz
Fuel recommendation	Diesel fuel specified to EN 590 or ASTM D975	
Fuel shutoff solenoid	Electric	
Fuel injection pump	Stanadyne	
Fuel pump priming	Manual	
Maximum recommended fuel lift, m (ft.)	0.9 (3.0)	

Lubrication

Lubricating System	60 Hz	50 Hz
Oil pan capacity with filter, L (U.S. qt.)	14.0 (14.8)	
Type	Pressure	

Operation Requirements

Air Requirements	60 Hz	50 Hz
Engine combustion air requirements, L/min. (cfm)	4502 (159)	3738 (132)
Cooling air required for generator set at 14°C (25°F) rise, m ³ /min. (cfm)	N/A	N/A
Exhaust gas flow, m ³ /min. (cfm)	14.2 (502)	11.9 (419)

Fuel Consumption	60 Hz	50 Hz
Diesel, Lph (gph) at % load		
100%	17.4 (4.6)	14.4 (3.8)
75%	13.2 (3.5)	10.6 (2.8)
50%	9.8 (2.6)	7.6 (2.0)
25%	5.7 (1.5)	4.2 (1.1)

Engine Features

- One-side serviceability of fuel system, lubrication system, and air cleaner
- Low oil pressure cutout
- High water temperature cutout
- Loss of coolant cutout
- Overcrank cutout
- Belt guard
- Optional oil pressure gauge, water temperature gauge, and battery voltage gauge
- Disposable oil filter
- Extended oil drain
- PTO options: 12- or 24-volt electric clutch

Controller Features

- Rubber mounted to isolate vibration
- Safety shutdowns
 - Engine overheating
 - Low oil pressure
 - Overcrank
- Safety shutdown lamp
- Shutdown reset switch
- Terminal strip connection for remote panel harness
- Hourmeter for scheduling maintenance
- Voltage-adjusting rheostat
- Start/stop switch

Controller Options

Decision-Maker™ 3+ Controller Features

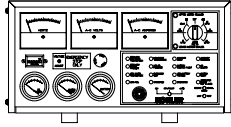

- Type: 16-light microprocessor (NFPA 110, level 1)
- Power source, with circuit protection: 12-volt DC
- Panel lamps (2)
- Analog Meters:
 - AC meters, 89 mm (3.5 in.) 2% full-scale accuracy on voltmeter and ammeter, 0.5% full-scale accuracy on frequency meter
 - DC meters, 51 mm (2 in.), volts, engine water temperature, oil pressure
 - Running time meter
- Switches and Controls:
 - Alarm horn and silencing switch
 - Cyclic cranking
 - Engine cooldown timer, 5 minute
 - Front-mounted voltage-adjusting rheostat $\pm 5\%$
 - Lamp-test switch
 - Local emergency stop button switch (optional)
 - Meter-phase selector switch, 7-position
 - Overvoltage protection shutdown
 - Prime power mode
 - Run/off-reset/auto switch (engine start), local/remote two-wire
- Fault and Condition Lamps:
 - Auxiliary fault (red)
 - Auxiliary prealarm (yellow)*
 - Battery charger fault (red)*
 - Emergency stop (red)*
 - Generator switch not-in-auto (red)
 - High engine temperature safety shutdown (red)
 - Low battery voltage (red)*
 - Low coolant level shutdown (auxiliary)
 - Low fuel (red)*
 - Low oil pressure safety shutdown (red)
 - Low water temperature (red)*
 - Overcrank safety shutdown (red)
 - Overspeed safety shutdown (red)
 - Prealarm high engine temperature (yellow)*
 - Prealarm low oil pressure (yellow)*
 - System ready (green)

* Requires an optional kit or a user-provided device for lamp to function.

Manual Controllers

- Standard Decision-Maker™ 1 controller
- Expanded Decision-Maker™ 1 controller with engine gauges and AC meters
(For manual controller features, see the marine controller spec sheet.)

Alternator Specifications

Alternator Specifications

Specifications	Fast-Response™ Generator
Manufacturer	Kohler
Type	4-pole, rotating-field
Exciter type	Brushless, permanent-magnet, Fast-Response™
Number of leads	12, reconnectable
Voltage regulator	Solid state, volts/Hz
Insulation: NEMA MG1-1.66	
Material	Class H
Temperature rise	120°C
Bearing: number, type	1, sealed
Coupling	Flexible disc
Amortisseur windings	Full
Voltage regulation, no load to full load	$\pm 2\%$
One-step load acceptance per NFPA 110	100% of rating
Peak motor starting kVA—4S7	270 (60 Hz), 190 (50 Hz)

Alternator Features

- The generator complies with NEMA, IEEE, and ANSI standards for temperature rise.
- The alternator uses a permanent-magnet, Fast-Response™ excitation system.
- The alternator has a two-thirds pitch stator and skewed rotor.
- The generator has a solid-state, volts-per-hertz voltage regulator.
- The brushless, synchronous generator is broadrange and reconnectable.
- The windings are vacuum-impregnated with fungus-resistant epoxy varnish.
- The generator sustains short-circuit current up to 300% of the rated current for up to 10 seconds.

Accessories/Options

- Electronic governor
- Fluid-filled isolation mounts
- Electric front clutch PTO (12- or 24-volt)
- Line circuit breaker
- DEC 3+ controller
- Sound shield
- Remote control panel
- Siphon break
- Overspeed shutdown kit
- Remote connection/extension harness
- Safeguard breaker
- Fuel filter
- Oil level indicator (high/low)
- Low coolant level indicator
- Crankcase emission canister

KOHLER[®] POWER SYSTEMS

KOHLER CO., Kohler, Wisconsin 53044 USA
Phone 920-565-3381, Fax 920-459-1646
For the nearest sales and service outlet in the
US and Canada, phone 1-800-544-2444
KohlerPowerSystems.com

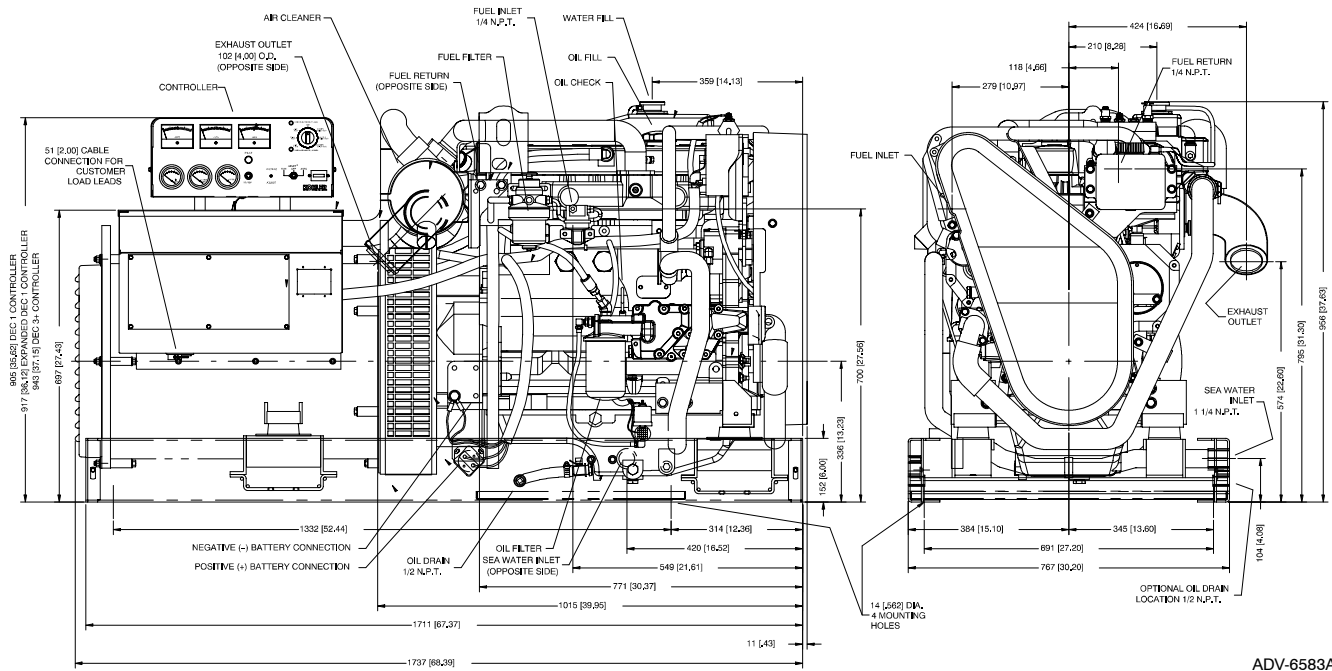

ADV-6583A-C

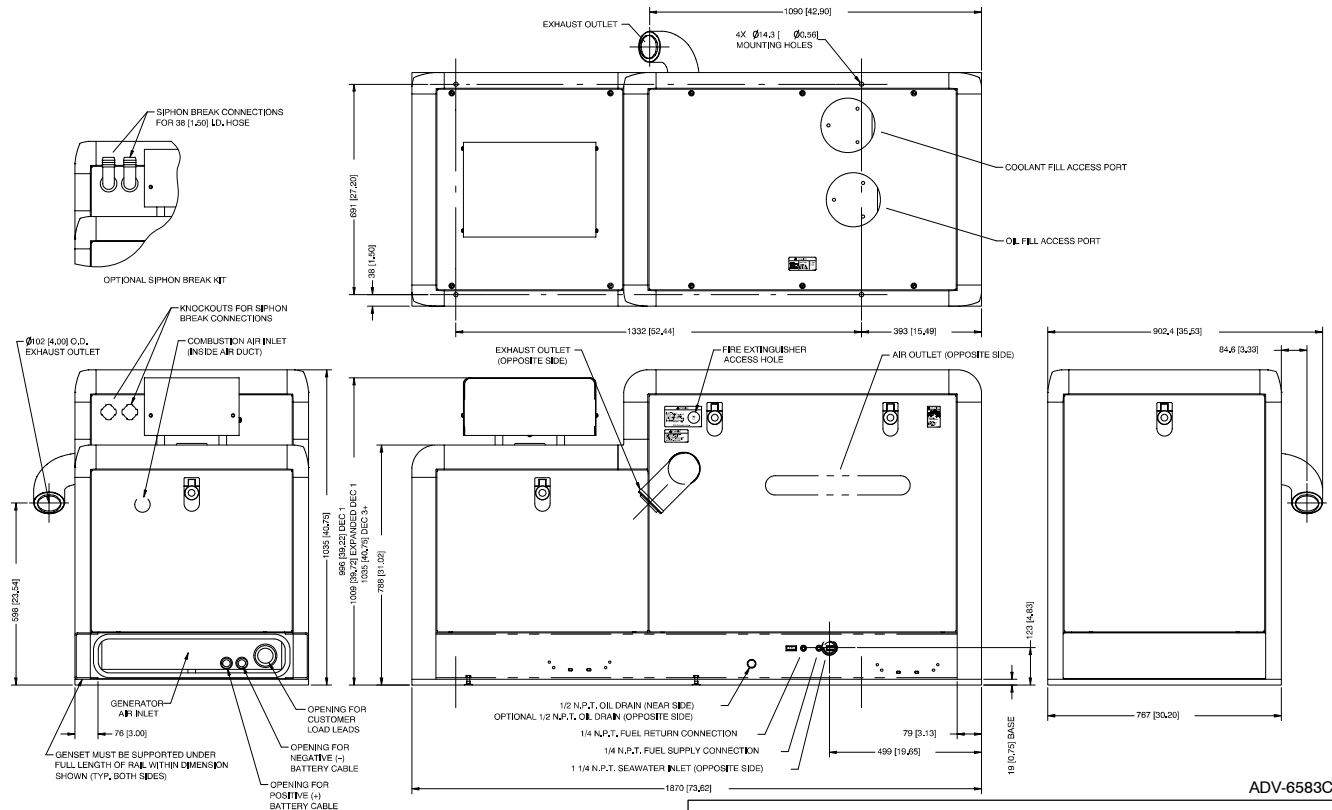

ADV-6583C-C

DISTRIBUTED BY:

NOTE: Dimensions in [] are inch equivalents.
NOTE: This drawing is provided for reference only and is not intended for installation planning. Contact your local distributor for more detailed information.

© 2000, 2002 by Kohler Co. All rights reserved.